



TÜV
CERT
EN ISO 9001:2000



www.ozkanpompa.com.tr



Özkan
POMPA SANAYİ

GK Hot Oil Pump

- Designed for the transfer of hot oil mineral and synthetic oils
- Quite and High Efficiency
- Pump Dimensions are Acceptable TS EN 733 Standart

GK Kızgın Yağ Pompası

- Kızgın Yağ, Mineral ve Sentetik Yağların Transferi için Tasarlanmıştır.
- Sessiz ve Yüksek Verimli
- Pompa Ölçüleri TSE EN 733 Standartlarına Uygundur.

1. Hot Oil Pump / Kızgın Yağ Pompası

Discharge Flange	: DN 32 ... DN 150 mm
Capacity	: 450 m ³ /h
Head	: 110 m
Speed	: 1450-2900 rpm
Operating Temperature	: 320°C
Cooling	: Air cooling
Pressure (Pmax)	: 16 bar
(Pmax= Suction Pressure + Head in Close Valve)	

Basma Flanşı	: DN 32 ... DN 150 mm
Debi	: 450 m ³ /h
Basma Yüksekliği	: 110 m
Hız	: 1450-2900 d/dak
Çalışma Sıcaklığı	: 320°C
Soğutma	: Hava ile
Gövde Basıncı (Pmaks)	: 16 bar
(Pmaks= Emme Basıncı + Kapalı Vanadaki Basma Yüksekliği)	

Dischargeable Liquids

All types of organic and synthetic oils which made for heat transfer and not include abrasive components.

Basılabilen Sıvılar

Isı transferi için imal edilmiş içinde aşındırıcı parçalar bulunmayan organik ve sentetik yağ çeşitlerinin tümü.

Usage Areas

- Chemical and Petrochemical Plants
- Paper Factories
- Sugar Factories
- Food and Medicine Factories
- Plastic, Rubber and Synthetic Fiber Factories
- Cooking and Heating Ovens (Furnaces)
- Textile and Leather Industry
- Iron-Steel Industry
- Paint Industry
- Asphalt and Bitumen Processing Industry
- Woodworking and Furniture Industries
- Heat Transfer Facilities Above 100°C

Kullanım Alanları

- Kimya ve Petrokimya Tesisleri
- Kağıt Fabrikaları
- Şeker Fabrikaları
- Gıda ve İlaç Fabrikaları
- Plastik, Kauçuk ve Sentetik Elyaf Fabrikaları
- Pişirme ve Isıtma Fırınlarında
- Tekstil ve Deri Endüstrisinde
- Demir-Çelik Sanayi
- Boya Sanayi
- Asfalt ve Bitümen İşleme Sanayi
- Ağaç İşleme ve Mobilya Sanayi
- 100°C'nin üzerindeki ısı transfer tesislerinde

Approximate Capacity Calculation

$V=Q/(Cp \cdot \rho \cdot \Delta T)$
V: Pump capacity (m³/h)
Q: Boiler heat capacity (kW or kcal/h)
Cp: Oil average specific heat (kJ/kg.K or kcal/kg.K)
ρ: Oil average density (kg/m³)
ΔT: Temperature difference (round-trip)

• Oils, using in hot oil pumps, commonly volumetric specific heat: (Between 200-350°C)
Cp. ρ=500 kcal/m³.K
◆ In usage of different oils, check the tables.
In this situation;
 $V=(Q(kcal/h))/(500 \cdot \Delta T)$ or $V=(Q(kW))/(500 \cdot \Delta T)$
(1kW=861 kcal/h)

• In practice, the difference between temperatures in round-trip is 18 to 48 °C. In this situation;
ΔT=18°C $V(m^3/h)=(Q(kcal/h))/9000=(Q(kW))/10,5$
ΔT=30°C $V(m^3/h)=(Q(kcal/h))/15000=(Q(kW))/17,4$
ΔT=42°C $V(m^3/h)=(Q(kcal/h))/21000=(Q(kW))/24,4$

Yaklaşık Debi Hesaplamaları

$V=Q/(Cp \cdot \rho \cdot \Delta T)$
V: Pompa Debisi (m³/h)
Q: Kazan ısı kapasitesi (kW veya kcal/h)
Cp: Yağın ortalama özgül ısısı (kJ/kg.K veya kcal/kg.K)
ρ: Yağın ortalama yoğunluğu (kg/m³)
ΔT: sıcaklık Farkı(gidiş-dönüş)

• Kızgın yağ pompalarında kullanılan yağların genelinin sahip olduğu hacimsel özgül ısı: (200-350°C aralığında)
Cp. ρ=500 kcal/m³.K
◆ Farklı yağ kullanımında gerekli özellikler ilgili tablolardan kontrol edilmeli. Bu durumda;
 $V=(Q(kcal/h))/(500 \cdot \Delta T)$ veya $V=(Q(kW))/(500 \cdot \Delta T)$
(1kW=861 kcal/h)

• Pratikte gidiş-dönüş sıcaklıkların farkı 18-42° C olarak alınmaktadır. Bu durumda;
ΔT=18°C $V(m^3/h)=(Q(kcal/h))/9000=(Q(kW))/10,5$
ΔT=30°C $V(m^3/h)=(Q(kcal/h))/15000=(Q(kW))/17,4$
ΔT=42°C $V(m^3/h)=(Q(kcal/h))/21000=(Q(kW))/24,4$

Code of Pump / Pompa Kodu

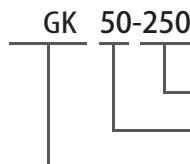

Impeller Diameter (mm) / Çark Anma Çapı (mm)
Discharge Flange (DN) / Basma Flanşı (DN)
Pump Type / Pompa Tipi

2.Materials / Malzemeler

	Ductile Cast Iron Sfero Dökme Demir	Chrome Steel Krom Çelik	Cast Iron Dökme Demir
Volute / Salyangoz	✓	✗	✗
Shaft / Mil	✗	✓	✗
Impeller / Çark	✗	✗	✓

2.1 Mechanical Seal / Mekanik Salmastra

1-) N-T01

Application: Clean water, sewage water, oil and other moderately corrosive fluids

Kullanım Yeri: Temiz su, kanalizasyon suyu, yağ ve diğer orta korozif akışkanlar

- Pressure / Basınç: 16 bar (230 PSI),

- Temperature / Sıcaklık:

Standard = -30 °C ... +200 °C (-22 °F ... +392 °F)



A-) Seal Face / Dönel Yüzey:

Carbon graphite antimony impregnated
Carbon graphite resin impregnated
Silicon carbide
Tungsten carbide

B-) Seat / Sabit Yüzey:

Silicon carbide
Ceramic
Tungsten carbide

C-) Elastomer / Elastomer:

NBR
EPDM
FKM
HNBR

D-) Metal Parts / Metal Parça:

CrNiMo steel,
Hastelloy® C-4

Pumps Dimensions / Pompa Ölçüleri

Pump Type Pompa Tipi	Mechanical Seal Mekanik Salmastra	Bearing Rulman
32-125	T01	6306
32-160	T01	6306
32-200	T01	6306
32-250	T01	6306
40-125	T01	6306
40-160	T01	6306
40-200	T01	6306
40-250	T01	6306
50-125	T01	6306
50-160	T01	6306
50-200	T01	6306
50-250	T01	6306
65-125	T01	6306
65-160	T01	6306
65-200	T01	6306
65-250	T01	6308
80-160	T01	6306
80-200	T01	6308
80-250	T01	6308
100-160	T01	6306
100-200	T01	6308
100-250	T01	6308
125-200	T01	6308
150-200	T01	6308

Thermal Oil Temperature Capability Curve / Kızgın Yağ Sıcaklık Kapasite Eğrisi

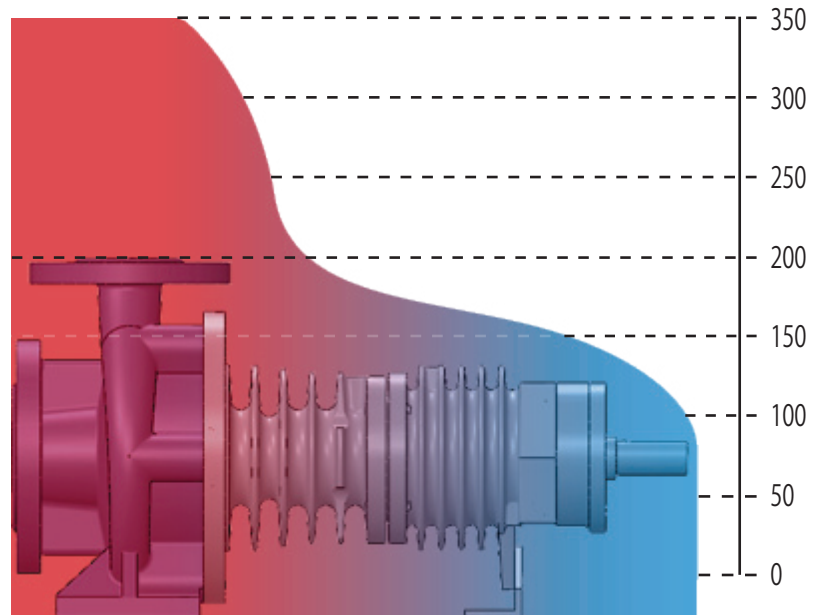

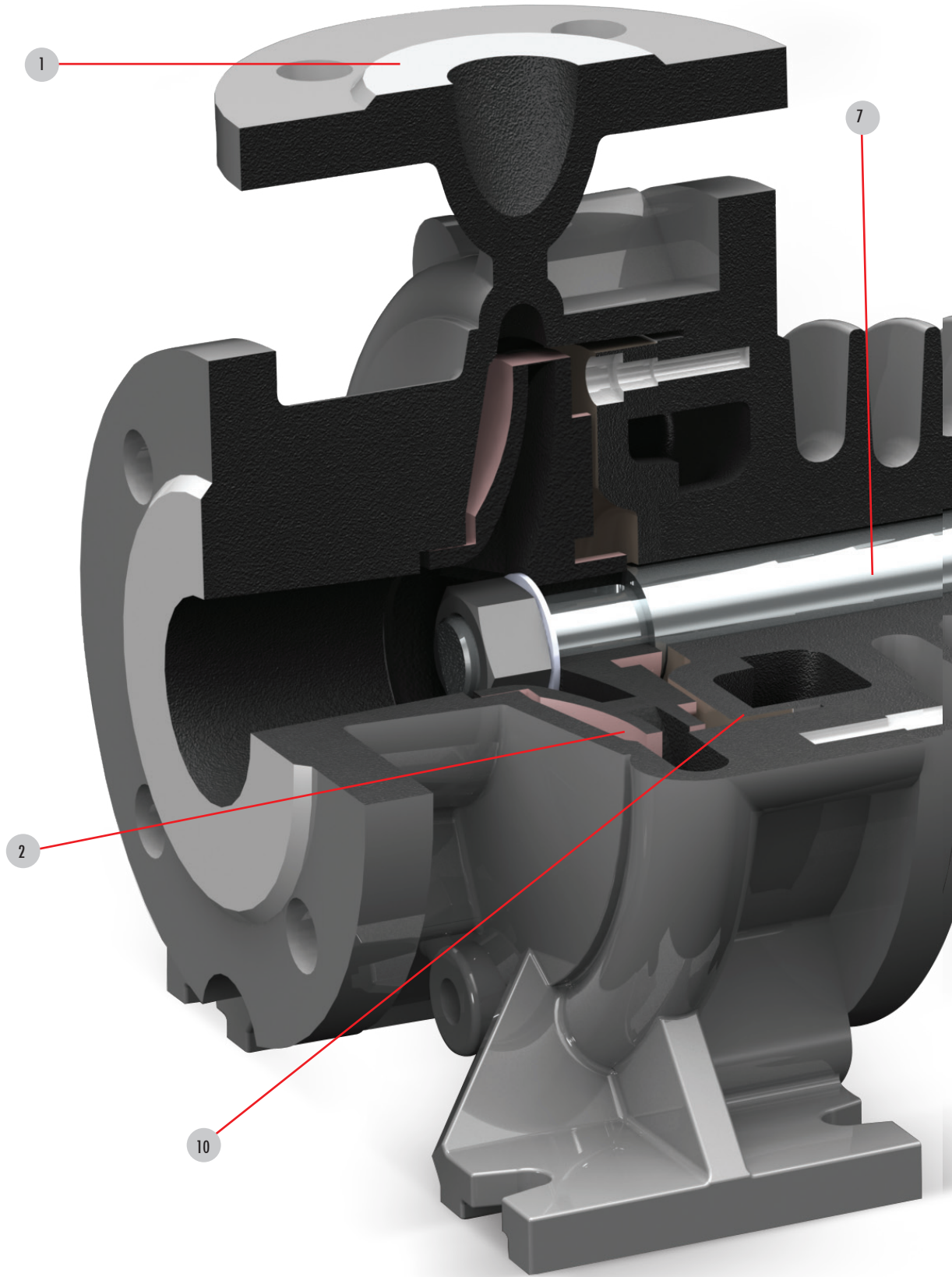

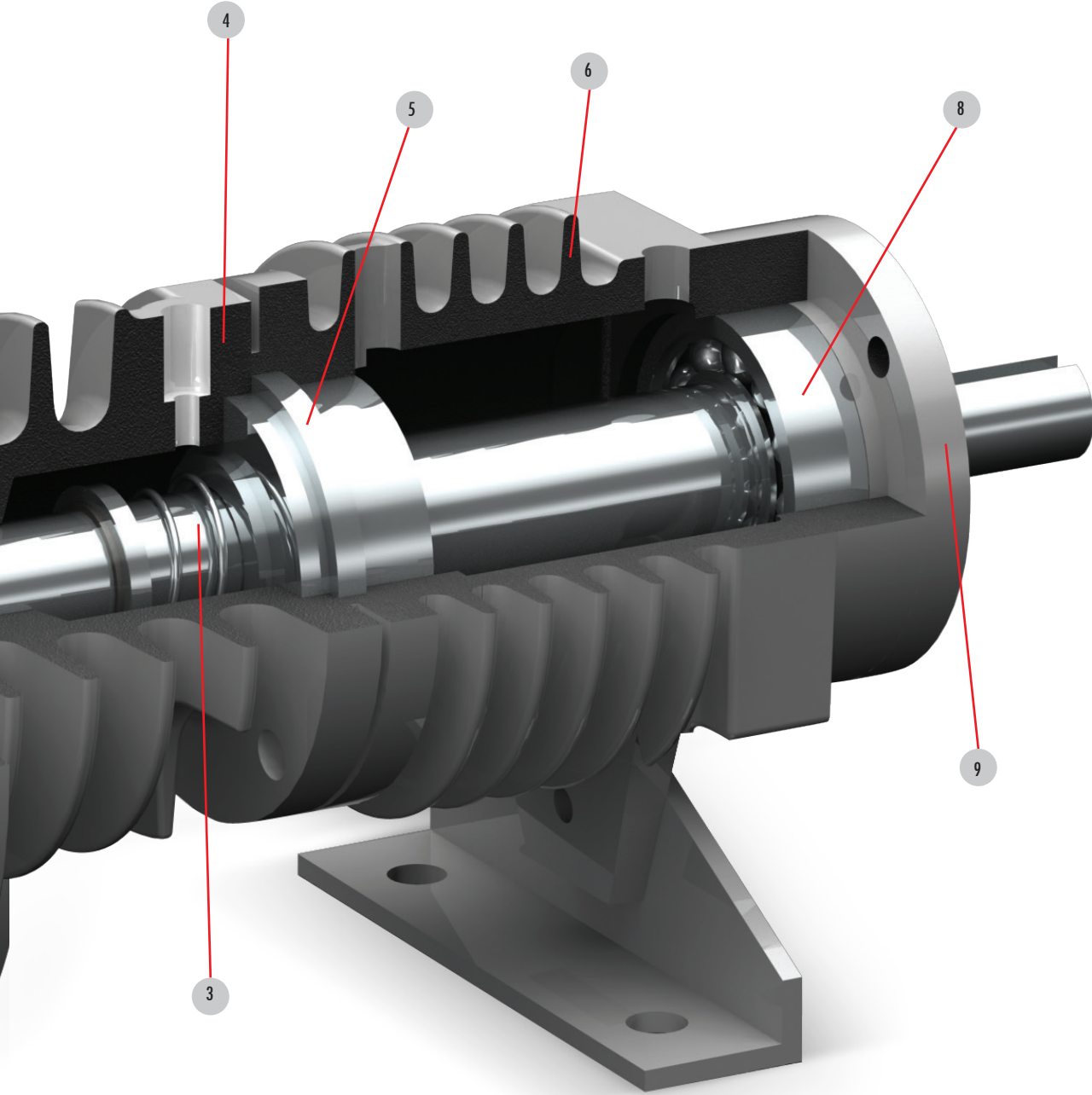

1 - Volute Casing	Salyangoz
2 - Impeller	Çark
3 - Seal (Mechanical Seal)	Mekanik Salmastra
4 - 1/4 NPT Casing Drain Plug	Hava Tahliye Tıpası
5 - Stuffing Box Cover	Salmastra Kutusu

6 - Bearing Box	Rulman Kutusu
7 - Shaft	Mil
8 - Bearing	Rulman
9 - Bearing Cover	Rulman Yatağı
10 - Corrosion Plate	Aşınma Plakası

GK Series 1450 RPM Performance Table
GK Serisi 1450 d/d Performans Tablosu

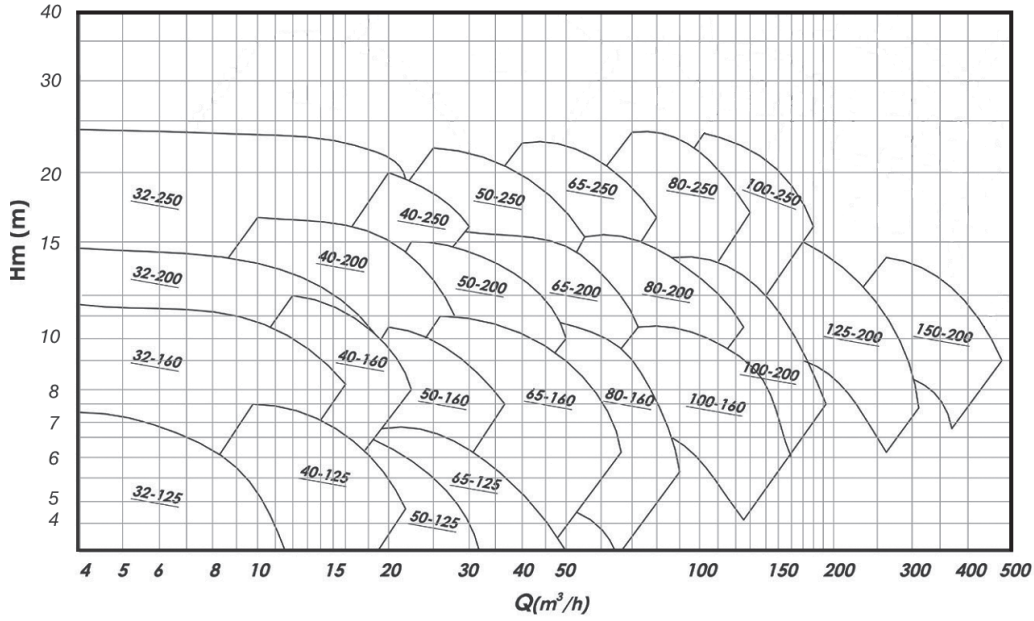

- GK Series pumps are testing with TSE EN ISO 9906 grades.
- This standart doesn't include mechanical properties, just include hydrolic properties.
- This standart has tolerance \pm % 8 flow rate, \pm %5 pressure and -%5 efficiency.
- Ozkan can supply their special customers to test reports for all pump if required.

- GK Serisi pompalar TSE EN ISO 9906 sınıf 2 standartlarına göre test edilmektedir.
- Bu standart sadece hidrolıklar içerir mekanik özellikler içermez
- Bu standart \pm % 8 debi, \pm % 5 basınç ve -%5 verim toleransına sahiptir.
- İstenilen ürünlerin performans eğrilerini firmamızdan isteyebilirsiniz.

GK Series 2900 RPM Performance Table
GK Serisi 2900 d/d Performans Tablosu

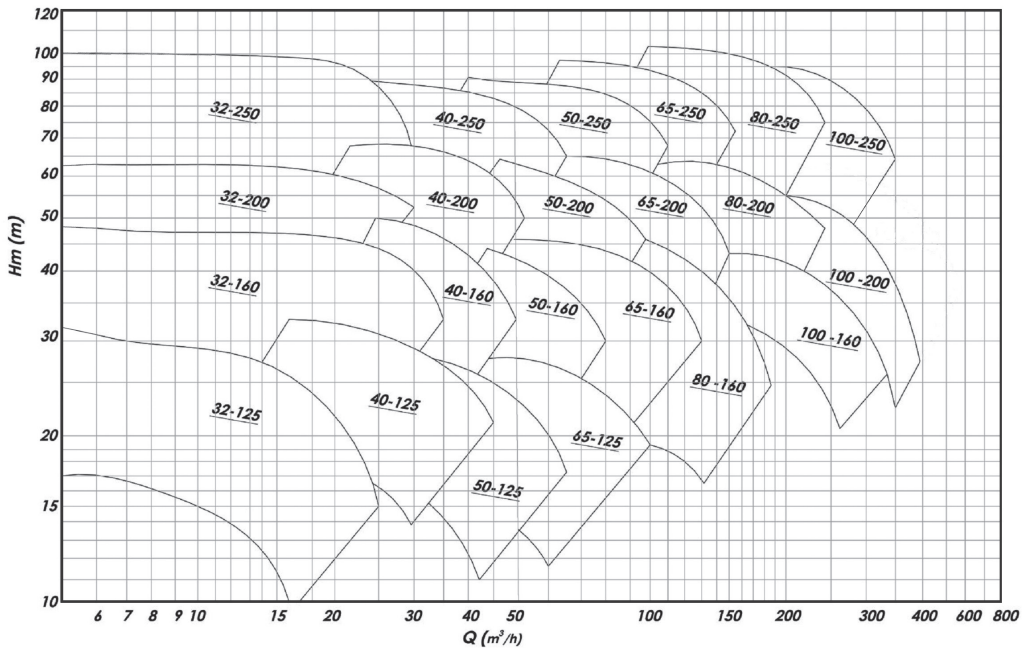

Pumps Dimensions / Pompa Ölçüleri

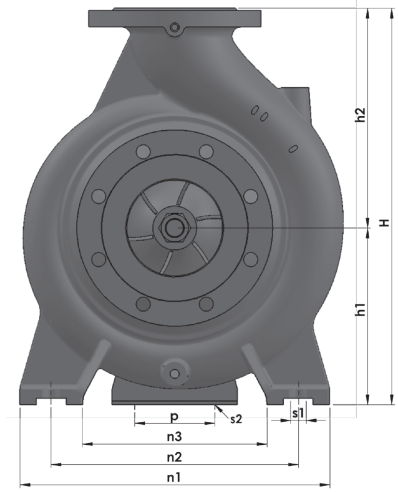
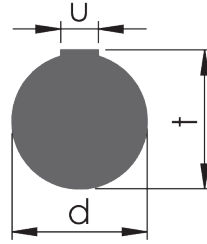
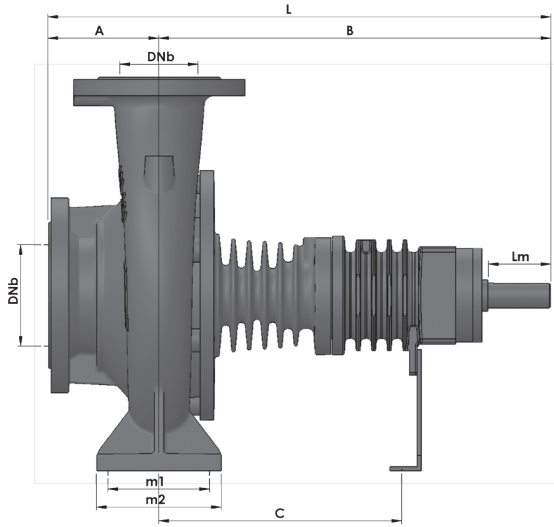

Pump Type Pompa Tipi	DIMENSIONS / ÖLÇÜLER (mm)																				Weight Ağırlık (kg)		
	Main Dimensions / Dış Ölçüler							Foot Dimensions / Ayak Bağlantı Ölçüleri							Shaft Dimensions Mil Ucu Ölçüleri								
	DNe	DNb	A	B	L	H	h1	h2	m1	m2	n1	n2	n3	s1	p	s2	C	d	Lm	t		u	
32-125	50	32	82	391	473	252	112	140	105	81	220	160	110	12	110	14	252	24	50	27	8	30	
32-160			79	392	471	292	132	160	103	79	240	190	140				253					34	
32-200			80	386	466	340	160	180	102	79	244	190	135				248					39	
32-250			102	389	491	405	180	225	126	100	320	260	188				14					251	49
40-125	65	40	80	391	471	252	112	140	100	79	208	160	110	13	110	14	252	24	50	27	8	32	
40-160			90	389	479	292	132	160	103	78	246	190	132	250			35						
40-200			100	388	488	340	160	180	102	77	270	214	158	12			246					40	
40-250			114	384	498	405	180	225	128	99	320	255	186	14			246					53	
50-125	65	50	100	390	490	292	132	160	100	77	240	190	140	12	110	14	251	24	50	27	8	35	
50-160			385	495	340	180	75	268		214	160	245	38										
50-200			110	383	493	360	160	200		108	80	269	216				147					244	43
50-250			101	387	488	405	180	225		124	97	316	248				176					249	56
65-125	80	65	100	391	491	340	160	180	125	102	280	215	150	14	110	14	252	24	50	27	8	39	
65-160			108	383	491	360	160	200	127	100	282	214	144	245			42						
65-200			104	384	488	405	180	225	136	109	323	255	186	246			47						
65-250			100	502	602	450	200	250	160	125	365	278	195	18			314					76	
80-160	100	80	126	390	516	405	180	225	126	99	331	263	194	12	110	14	252	24	50	27	8	47	
80-200			130	499	629	430	250	102		345	280	201	16	312			73						
80-250			127	501	628	480	200	280		160	125	405	317	235			18					313	80
100-160			120	399	519	480	200	280		160	125	363	278	193			18					261	68
100-200	125	100	127	506	633	480	200	280	160	130	360	285	206	20	110	14	318	24	50	27	8	72	
100-250			142	502	644	505	225	280		126	395	315	235	18			314					85	
125-200	150	125	143	511	654	565	250	315	160	130	400	315	244	18	110	14	323	32	80	35	10	89	
150-200	200	150	162	513	675	635	280	355		204	158	513	403	293			20					323	32

Pump Type Pompa Tipi	FLANGE DIMENSIONS / FLANŞ ÖLÇÜLERİ											
	SUCTION / EMME (PN 16)						DISCHARGE / BASMA (PN)					
	DNe	Df	k	s	n	bf	DNb	Df	k	s	n	bf
32	50	165	125	18	4	20	32	140	100	18	4	18
40	65	185	145	18	4	20	40	150	110	18	4	18
50	65	185	145	18	4	20	50	165	125	18	4	20
65	80	200	160	18	8	22	65	185	145	18	4	20
80	100	220	180	18	8	24	80	200	160	18	8	22
100	125	250	210	18	8	26	100	220	180	18	8	24
125	150	285	240	23	8	26	125	250	210	18	8	26
150	200	340	295	23	12	30	150	285	240	23	8	26

